

# MIX&MATCH

Design by STUDIO P

## TMA.361T.MAX

WALL MOUNTED THERMOSTATIC  
MIXER WITH 3 EXITS WITH DIVERTER  
FOR 2 INDEPENDENT EXITS

### BODY MATERIAL

BRASS

### COMPATIBILITY

MIX&MATCH

### WORKING PRESSURE

0.5 to 5 bar

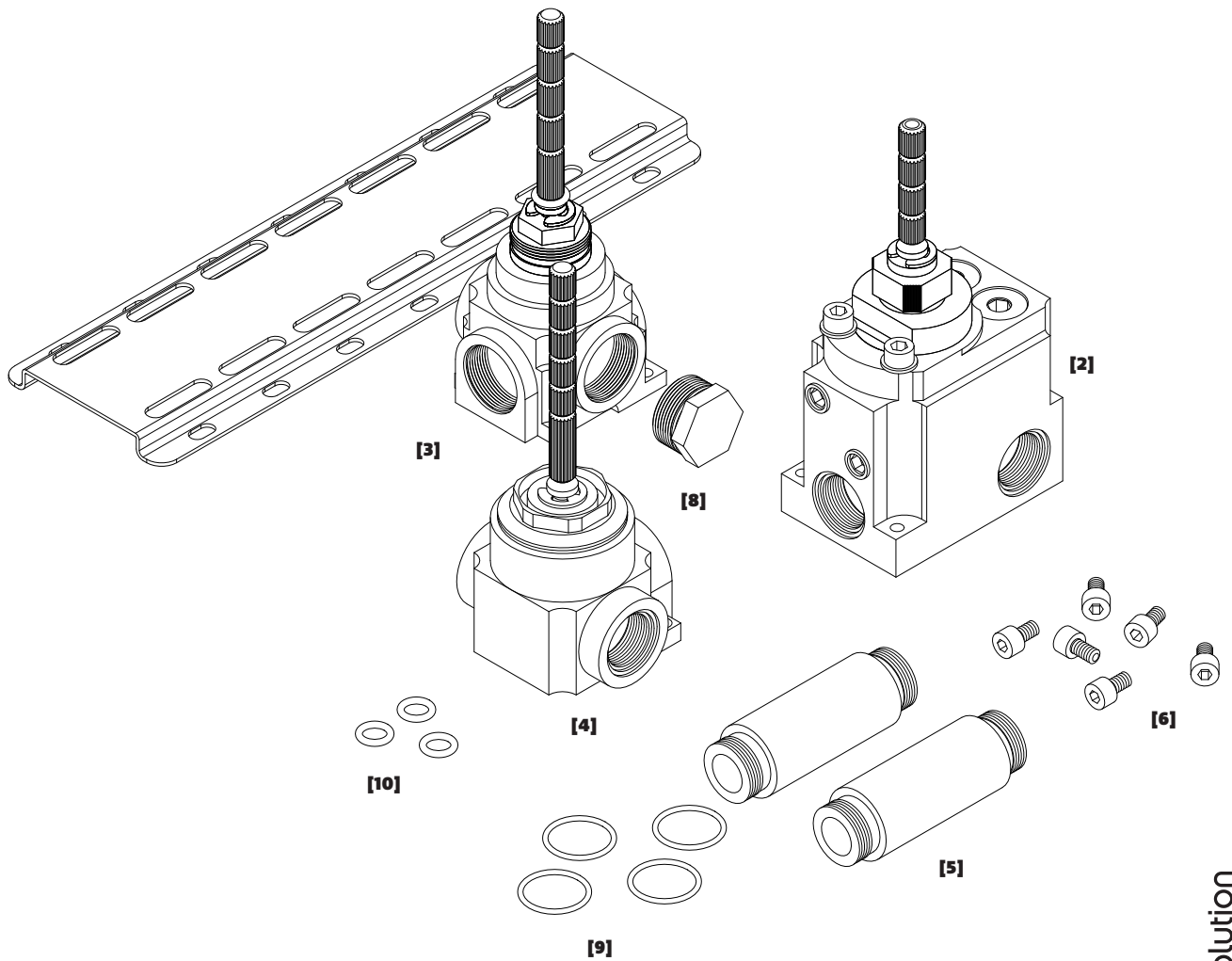

**CONTENTS**

- [1] FIXING PLATE
- [2] THERMOSTATIC VALVE SEAT
- [3] PASSAGE STOP VALVE
- [4] 2 WAYS DIVERTER
- [5] CONNECTION PIPE
- [6] FIXING SCREW
- [7] CHECK VALVE
- [8] HALF INCH CAP
- [9] CONNECTION PIPE O RING
- [10] HEADWORKS O RING
- [11] FASTENING NUT

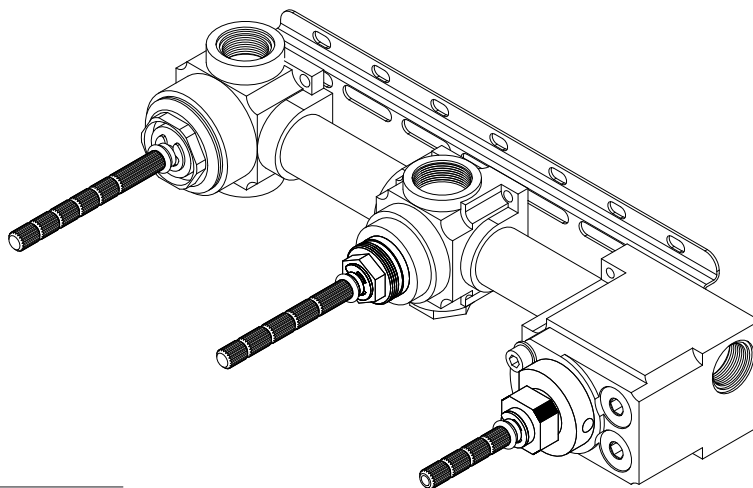

**BUILT-IN**

[X] MIN. 94MM/MÁX. 113MM

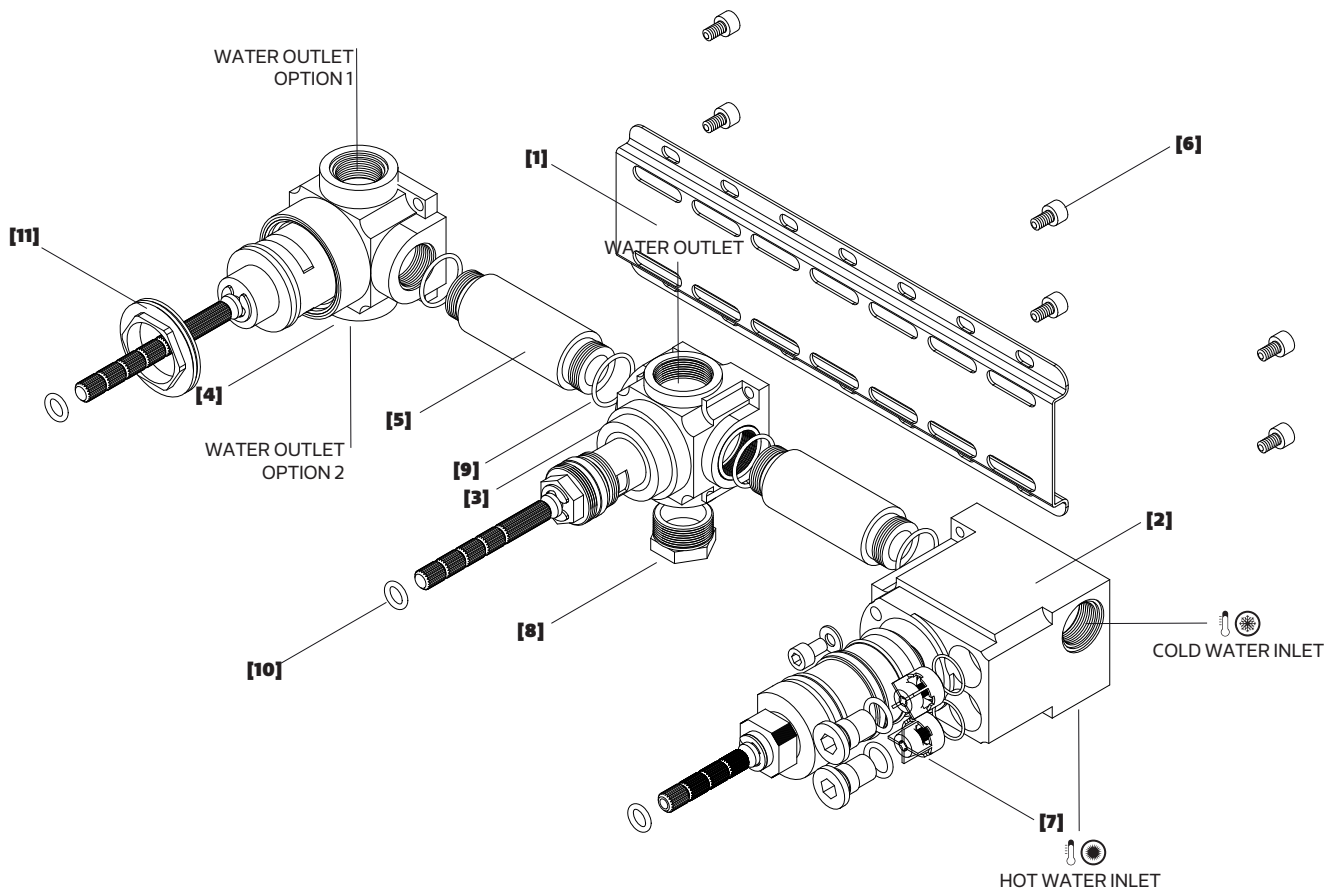

**WATER SUPPLY**

FLUSH WATER SUPPLY LINES THOROUGHLY BEFORE INSTALLING THE TAP. DO NOT ALLOW DIRT, TEFLON TAPE OR METAL PARTICLES TO ENTER THE TAP. SHUT OFF THE WATER SUPPLY BEFORE INSTALLATION. GRAVITY-FED SYSTEMS MAY REQUIRE A BOOSTER PUMP TO ACHIEVE THE OPTIMAL OPERATING PRESSURE.

**BEFORE INSTALLATION**

CHECK FOR HIDDEN EXISTING PIPEWORK AND ELECTRICAL CABLES BEFORE DRILLING THE WALL

**MAINTENANCE**

WE RECOMMEND ONLY WARM SOAPY WATER IN THE CLEANING OF THIS PRODUCT. DO NOT USE LIQUID DETERGENTS CONTAINING ABRASIVE OR ACIDIC ADDITIVES. THE USE OF THIS TYPE OF PRODUCT MAY PERMANENTLY DAMAGE THE FINISH OF THE PRODUCT AND WILL INVALIDATE THE MANUFACTURERS WARRANTY.

